

# Sealed 4-Ball Plus Lowers

2500cc, 3000cc, and 4000cc Models

3A5348J  
EN

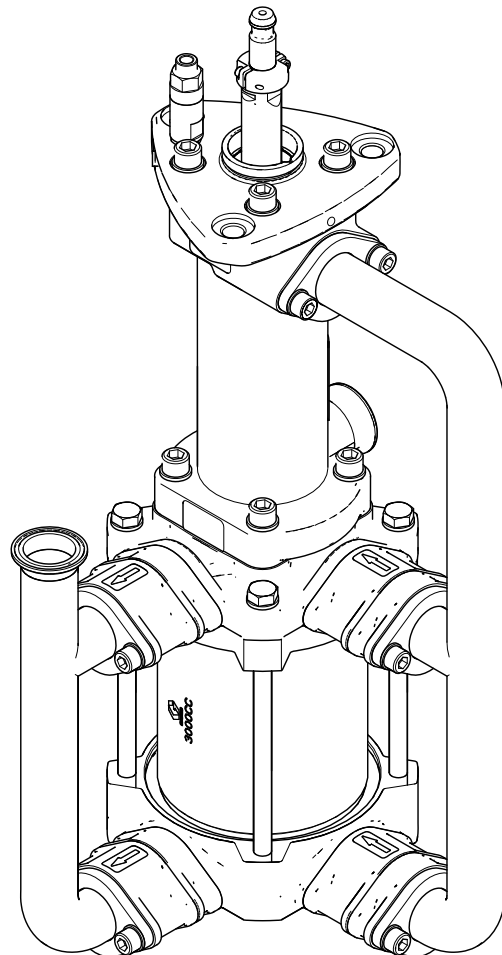
***Designed for low-pressure, high-volume circulation of finishing materials.  
Do not use for flushing or purging lines with caustics, acids, abrasive line strippers, or  
other similar fluids. For professional use only.***

See page 21 for technical specifications, including maximum working pressure.



## **Important Safety Instructions**

Read all warnings and instructions in this manual and in your separate pump manual before using the equipment. Save these instructions.



ti32110a

# Contents

<b>Related Manuals</b> .....	<b>3</b>	<b>Repair Kits</b> .....	<b>18</b>
<b>Models†</b> .....	<b>3</b>	Connection Kits .....	18
<b>Options When Ordering the Lower</b> .....	<b>3</b>	<b>Dimensions</b> .....	<b>19</b>
<b>Warnings</b> .....	<b>4</b>	<b>Technical Specifications</b> .....	<b>21</b>
<b>Repair</b> .....	<b>6</b>	<b>California Proposition 65</b> .....	<b>21</b>
Full Lower Disassembly .....	6	<b>Graco Standard Warranty</b> .....	<b>22</b>
Full Lower Reassembly .....	8	<b>Graco Information</b> .....	<b>22</b>
Replace the Bellows .....	13		
<b>Parts (All Models)</b> .....	<b>15</b>		

## Related Manuals

Manual	Description
3A6938	High-Flo <sup>®</sup> Plus 4-Ball Pumps
3A6939	Viscount <sup>®</sup> High-Flo Plus Pumps
3A6937	E-Flo <sup>®</sup> DC High-Flo Plus Pumps
3A3453	E-Flo <sup>®</sup> DC 2000, 3000, 4000, and 5000 Circulation Pumps
311876	4-Ball Lower Retrofit Connection Kits
3A7828	E-Flo <sup>®</sup> DCi Sealed 4-Ball Pumps

## Models<sup>‡</sup>

Model Description	Sizes		
	2500cc Lower	3000cc Lower	4000cc Lower
Ultralife Cylinders			
Standard Top Plate Rotation*	17Z387	17Z388	17Z389
90° Top Plate Rotation*	17Z695	17Z696	17Z697
180° Top plate Rotation*	17Z698	17Z699	17Z700
Ultralife Cylinders with Silicon Nitride Balls			
Standard Top Plate Rotation	18F379	18F380	18F381
Chrome Cylinders			
Standard Top Plate Rotation*	17Z390	17Z391	17Z392
90° Top Plate Rotation*	N/A		
180° Top plate Rotation*			

<sup>‡</sup> All models will require a connection kit when connecting the new lower to an existing motor. See **Connection Kits** on page 18.

\* See **Dimensions**, page 19, for top plate rotation orientations.




## Options When Ordering the Lower

Cylinder/rod coating options include Ultralife and Chrome:

- Choose Ultralife for most applications.
- Choose Chrome for fine pigment paint and fluids with low lubrication such as solvents and water.

# Warnings

The following warnings are for the setup, use, grounding, maintenance, and repair of this equipment. The exclamation point symbol alerts you to a general warning and the hazard symbols refer to procedure-specific risks. When these symbols appear in the body of this manual or on warning labels, refer back to these Warnings. Product-specific hazard symbols and warnings not covered in this section may appear throughout the body of this manual where applicable.

 <h2 style="margin: 0;">WARNING</h2>	
	<p><b>FIRE AND EXPLOSION HAZARD</b></p> <p>Flammable fumes, such as solvent and paint fumes, in <b>work area</b> can ignite or explode. Paint or solvent flowing through the equipment can cause static sparking. To help prevent fire and explosion:</p> <ul style="list-style-type: none"> <li>• Use equipment only in well ventilated area.</li> <li>• Eliminate all ignition sources; such as pilot lights, cigarettes, portable electric lamps, and plastic drop cloths (potential static sparking).</li> <li>• Ground all equipment in the work area. See <b>Grounding</b> instructions.</li> <li>• Never spray or flush solvent at high pressure.</li> <li>• Keep work area free of debris, including solvent, rags and gasoline.</li> <li>• Do not plug or unplug power cords, or turn power or light switches on or off when flammable fumes are present.</li> <li>• Use only grounded hoses.</li> <li>• Hold gun firmly to side of grounded pail when triggering into pail. Do not use pail liners unless they are anti-static or conductive.</li> <li>• <b>Stop operation immediately</b> if static sparking occurs or you feel a shock. Do not use equipment until you identify and correct the problem.</li> <li>• Keep a working fire extinguisher in the work area.</li> </ul>
	<p><b>PRESSURIZED EQUIPMENT HAZARD</b></p> <p>Fluid from the equipment, leaks, or ruptured components can splash in the eyes or on skin and cause serious injury.</p> <ul style="list-style-type: none"> <li>• Follow the <b>Pressure Relief Procedure</b> when you stop spraying/dispensing and before cleaning, checking, or servicing equipment.</li> <li>• Tighten all fluid connections before operating the equipment.</li> <li>• Check hoses, tubes, and couplings daily. Replace worn or damaged parts immediately.</li> </ul>

# WARNING



## EQUIPMENT MISUSE HAZARD

Misuse can cause death or serious injury.

- Do not operate the unit when fatigued or under the influence of drugs or alcohol.
- Do not exceed the maximum working pressure or temperature rating of the lowest rated system component. See **Technical Specifications** in all equipment manuals.
- Use fluids and solvents that are compatible with equipment wetted parts. See **Technical Specifications** in all equipment manuals. Read fluid and solvent manufacturer's warnings. For complete information about your material, request Safety Data Sheet (SDS) from distributor or retailer.
- Turn off all equipment and follow the **Pressure Relief Procedure** when equipment is not in use.
- Check equipment daily. Repair or replace worn or damaged parts immediately with genuine manufacturer's replacement parts only.
- Do not alter or modify equipment. Alterations or modifications may void agency approvals and create safety hazards.
- Make sure all equipment is rated and approved for the environment in which you are using it.
- Use equipment only for its intended purpose. Call your distributor for information.
- Route hoses and cables away from traffic areas, sharp edges, moving parts, and hot surfaces.
- Do not kink or over bend hoses or use hoses to pull equipment.
- Keep children and animals away from work area.
- Comply with all applicable safety regulations.



## MOVING PARTS HAZARD

Moving parts can pinch, cut or amputate fingers and other body parts.

- Keep clear of moving parts.
- Do not operate equipment with protective guards or covers removed.
- Pressurized equipment can start without warning. Before checking, moving, or servicing equipment, follow the **Pressure Relief Procedure** and disconnect all power sources.



## TOXIC FLUID OR FUMES HAZARD

Toxic fluids or fumes can cause serious injury or death if splashed in the eyes or on skin, inhaled, or swallowed.

- Read Safety Data Sheet (SDS) to know the specific hazards of the fluids you are using.
- Store hazardous fluid in approved containers, and dispose of it according to applicable guidelines.



## PERSONAL PROTECTIVE EQUIPMENT

Wear appropriate protective equipment when in the work area to help prevent serious injury, including eye injury, hearing loss, inhalation of toxic fumes, and burns. Protective equipment includes but is not limited to:

- Protective eyewear, and hearing protection.
- Respirators, protective clothing, and gloves as recommended by the fluid and solvent manufacturer.

# Repair

## Full Lower Disassembly

See **Repair Kits**, page 18, for a complete list of available repair kits. To replace the bellows without a full pump disassembly, see **Reassemble the Bellows Assembly**, page 9.

### Preparation for Disassembly



This equipment stays pressurized until pressure is manually relieved. To help prevent serious injury from pressurized fluid, such as splashing fluid and moving parts, follow the **Pressure Relief Procedure** when you stop spraying and before cleaning, checking, or servicing the equipment.

1. Flush the pump, if possible.
2. Stop the pump at the top of its stroke.
3. Relieve the pressure. Follow the **Pressure Relief Procedure** in your separate pump manual.
4. Remove the lower from the motor as described in your separate pump manual.

### Weep Hole

#### NOTICE

Throat seal lubricant (TSL) is not to be used with this pump.

The weep hole in the pump mount plate (15) functions as a drain for TSL that may have been applied to the back up seal, and in case the back up seal is missing or damaged. The pipe plug (31) is used for some options See figure 1.

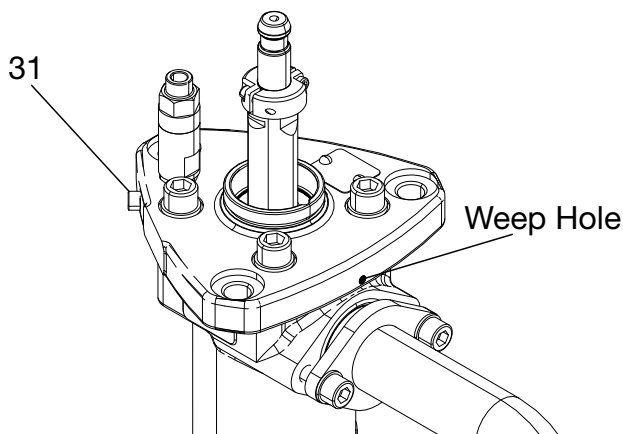


FIG. 1.

## Remove Checks and Side Manifolds

See **Parts (All Models)**, page 15, for an exploded view of the parts.

1. Secure the lower fluid housing (7) in a vise.
2. With a waste container in place, remove the two drain plugs (50). Drain as much of the leftover fluid as possible.
3. Inspect the pressure relief valve (48) to make sure it is not clogged. Press down on the ball of the valve to make sure that the ball and the spring are able to move.

**NOTE:** The relief valve (48) is not a plug and should not be installed in a plug location. The relief valve must always be installed in the upper fluid housing (8) directly across from the inlet manifolds.

#### NOTICE

The ball and spring need to move freely in the upper fluid housing (8). If the pressure relief valve is clogged or filled with material, the pump may over pressurize, causing leakage and possible seal damage. To prevent potential clogging, clean the relief valve and soak the seat in a compatible solvent. Remove all material residues from the ball and seat area of the housing. If the ball and spring still do not move freely, replace the valve assembly (48).

4. Starting with the lower checks, remove the ten bolts (45, 46) holding the manifolds and checks to the pump. Fluid will drain from the manifolds when the bolts are loosened. Support the check housings as the bolts are removed, so that the check housings do not fall off.

**NOTE:** Be careful not to drop or damage the balls (39) or seats (38). A damaged ball or seat cannot seal properly and fluid will leak past the check valve, causing the pump to operate improperly.

## Disassemble the Bellows Section

See FIG. 9, page 12.

For all lubricants and adhesives, see the notes listed in **Parts (All Models)** on page 15.

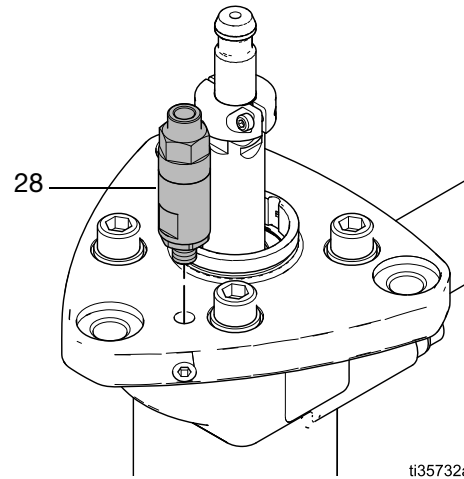
1. Remove the retaining collar (20) by removing the screws (21).
2. Remove the four capscrews (33) and lock washers (10) from the top plate (15).
3. Carefully lift the top plate (15) off of the bellows chamber (13). Keep the top plate (15) level.

**NOTE:** See FIG. 3, page 8. The retaining ring (27), retaining washer (26), bearing housing (16), bearing (17) and backup seal (18) nest in the top plate and will slide off with the top plate (29).

4. If the bellows has failed, also remove the breather valve (28) from the top plate. Clean the fluid path of any clogged paint.

### NOTICE

If the bellows has failed, the breather valve (28) must also be replaced and the fluid path must be cleared of paint. Failure to replace the breather valve may cause potential damage and premature wear to your bellows.



**FIG. 2. Breather Valve**

5. Remove the bellows o-ring (19).
6. Remove the bellows assembly from the bellows chamber.

**NOTE:** The bellows assembly includes the bellows nut (25), the bellows (14), o-rings (23, 24), and the bellows sleeve (22). To disassemble, see **Disassemble the Bellows Assembly** on page 8 and FIG. 4 on page 9.

7. Remove the four capscrews (33) from around the base of the bellows chamber (13). Lift the bellows chamber straight up off the fluid outlet housing (8). Be careful not to damage the piston rod (3).

## Disassemble the Fluid Section

See **Parts (All Models)**, page 15, for an exploded view of the parts.

1. Remove the throat cartridge (29).
2. Remove the four screws (11) and lock washers (10). Lift off the top pump housing (8).

**NOTE:** The cylinder (6) and piston assembly may come loose with the top fluid housing (8), or may remain in place on the bottom fluid housing (7).

3. Remove the cylinder (6). Pull the piston assembly out of the cylinder (6). Inspect the surface of the

## Disassemble the Bellows Assembly

See FIG. 4, page 9.

1. Clamp the flats of the bellows sleeve (22) in a vise.
2. Use a wrench on the flats of the bellows nut (25) to remove it from the bellows sleeve.
3. Remove o-rings (24, 25) from inside of the bellows sleeve (22).
4. Work the bellows (14) up and off the bellows sleeve (22).

## Disassemble the Throat Cartridge

See FIG. 5, page 9.

To disassemble the throat cartridge, remove the throat nut (30), o-ring (37), lip seal (35) and both o-rings (36).

## Disassemble the Piston Assembly

See FIG. 6, page 10.

Place the flats of the piston nut (4) in a vise. Unscrew the rod (3) from the piston nut (4). Remove the piston (1), seal (2) and spacer (5).

## Clean All Parts

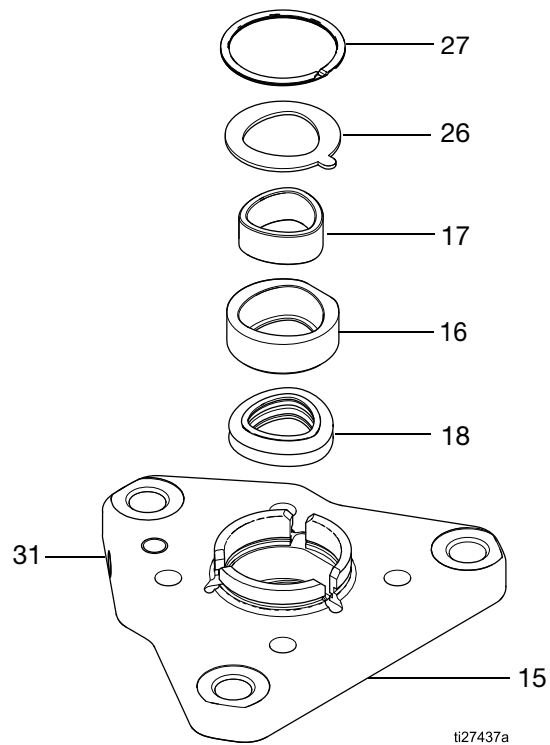
Clean all parts in a compatible solvent. Inspect all parts for wear or damage. If you are using a repair kit, use all the new parts in the kit, discarding the old ones they replace. Replace any other parts as needed. Worn or damaged parts may cause the pump to perform poorly or cause premature wear of the new seals and packings.

## Full Lower Reassembly

### Reassemble the Top Plate

For all lubricants and adhesives, see the notes listed in **Parts (All Models)** on page 15.

1. Apply lubricant to the backup seal (18).
2. Install the backup seal (18). Be sure the seal seats completely. Use a press if needed.
3. Install the bearing housing (16), bearing (17), retaining washer (26), and the retaining ring (27) into the top plate (15).



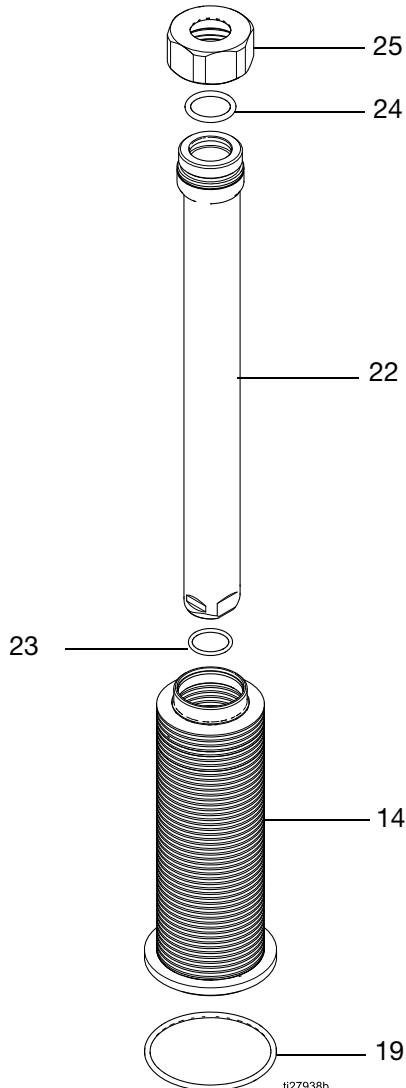
**FIG. 3. Top Plate Assembly**



### Reassemble the Bellows Assembly

For all lubricants and adhesives, see the notes listed in **Parts (All Models)** on page 15.

1. Lubricate and install the o-ring (23).
2. Slide the new bellows (14) onto the bellows sleeve (22) and snap it into place.
3. Clamp the flats of the bellows sleeve (22) in a vise.
4. Lubricate and install o-ring (24).
5. Apply the anti-seize lubricant to the inner diameter of the bellows nut (25).
6. Install the bellows nut (25) and torque to 25-30 ft-lb (34-41 N•m).
7. Lubricate and install the bellows o-ring (19).

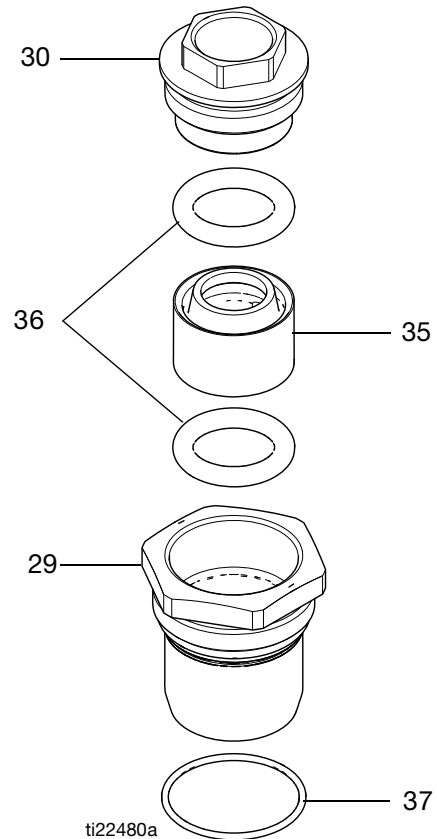


**FIG. 4. Disassemble or Assemble the Bellows**

### Reassemble the Throat Cartridge

For all lubricants and adhesives, see the notes listed in **Parts (All Models)** on page 15.

1. Apply lubricant to the o-rings (36). Install one o-ring (36) into the throat cartridge (29). Install the lip seal (35). Install one o-ring (36). Apply thread lubricant to the outside threads of the throat nut (30) and thread it into the cartridge (29). Hand tighten in place.
2. Apply lubricant to the o-ring (37). Slide the o-ring (37) onto the outside edge of the throat cartridge (29) until the o-ring (37) seats in the groove.



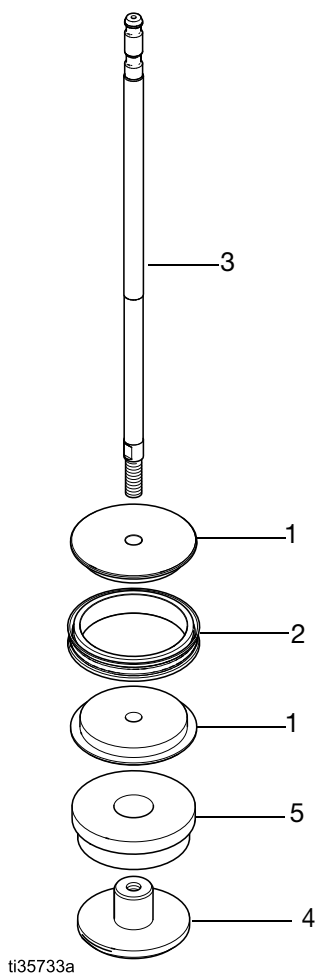
**FIG. 5. Disassemble or Assemble the Throat Cartridge**

## Reassemble the Piston Assembly

For all lubricants and adhesives, see the notes listed in **Parts (All Models)** on page 15.

**NOTE:** If reassembling the 2500cc piston assembly, it may be easier to complete steps 1 and 2 while the parts are inside the lubricated cylinder (6).

1. Place the halves of the piston (1) around the piston seal (2) and snap them together. See FIG. 6.
2. Apply high strength (red) Loctite® 268, 263, or 2760 to the outer diameter threads on the rod (3), applying 360° around the thread. Screw the rod (3) through the piston (1) and spacer (5) into the piston nut (4). Torque the piston nut (4) to 95-100 ft-lb (129-135 N•m). Sealant must be allowed to cure for a minimum of 12 hours before use.



**FIG. 6. Disassemble or Assemble the Piston**

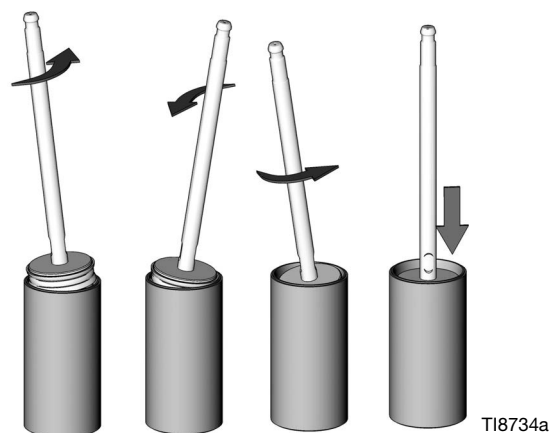
## Reassemble the Fluid Section

For all lubricants and adhesives, see the notes listed in **Parts (All Models)** on page 15.

### NOTICE

The relief valve (48) must be installed in the upper pump housing (8), as viewed in **Parts (All Models)**, page 15. The relief valve reduces the risk of pump overpressurization, which may cause damage to the pump.

1. Reinstall the plugs (50, 52) into the upper (8) and lower (7) fluid housing.
2. Install the pressure relief valve (48) in the upper housing (8) directly across from where the inlet manifold will be attached (49). Torque the pressure relief valve (48) to 100-135 in-lb (11-15 N•m).
3. Mount the lower (7) housing in a vise.
4. Install the pump rod assembly into the cylinder (6). Lubricate the inside of the cylinder (6). Slide the piston assembly into the cylinder (6). Rotate the piston assembly as shown in FIG. 7.



**FIG. 7. Install Piston in Cylinder**

5. Place a cylinder gasket (9) into the lower housing (7), using grease to hold it in place, and then place the cylinder (6) in the lower housing (7).
6. Apply thread lubricant to the outside threads on the throat cartridge (29) and loosely thread the assembled cartridge into the fluid outlet housing (8).

7. Place a cylinder gasket in the upper housing, using grease to hold it in place. Install the upper housing over the piston rod and onto the cylinder. Make sure that the inlet and outlet ports on the housings are aligned. Apply thread lubricant and install the bolts and lock washers through the upper housing and into the lower housing. Hand tighten these bolts. Tighten bolts (11) uniformly, verifying that the cylinder gasket (9) is not pinching and is in place. Torque bolts (11) to 40-45 ft-lb (54-61 N•m).
8. Torque the throat cartridge (29) to 70-75 ft-lb (95-102 N•m). Torque the throat nut (30) to 25-30 ft-lb (34-41 N•m).

### Reassemble the Bellows Section

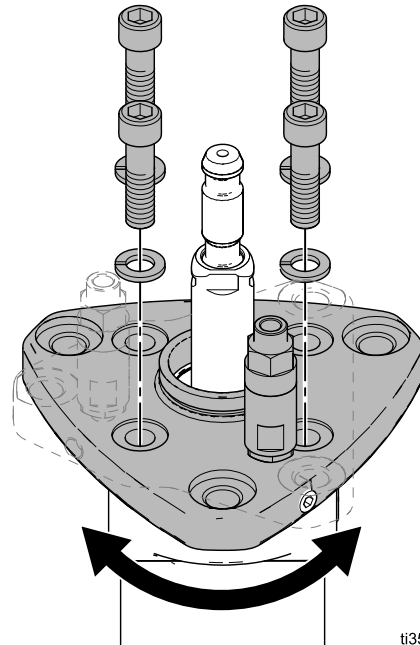
For all lubricants and adhesives, see the notes listed in **Parts (All Models)** on page 15.

1. Install the o-ring (12) in the top of the upper fluid housing (8).
2. Set the bellows chamber (13) onto the upper fluid housing (8) being careful not to damage the piston rod (3).
3. Apply removable (blue) Loctite<sup>®</sup> 243 to entire length of the threads on the capscrews (33). Install the four capscrews (33) with lock washers (10) to fasten the bellows chamber (13) to the upper fluid housing (8). Tighten the capscrews (33) uniformly and torque to 40-45 ft-lb (54-61 N•m).
4. Insert the bellows assembly over the piston rod (3) and into the bellows chamber (13).
5. Lubricate and install the bellows o-ring (19).

### Install the Top Plate and Side Manifold

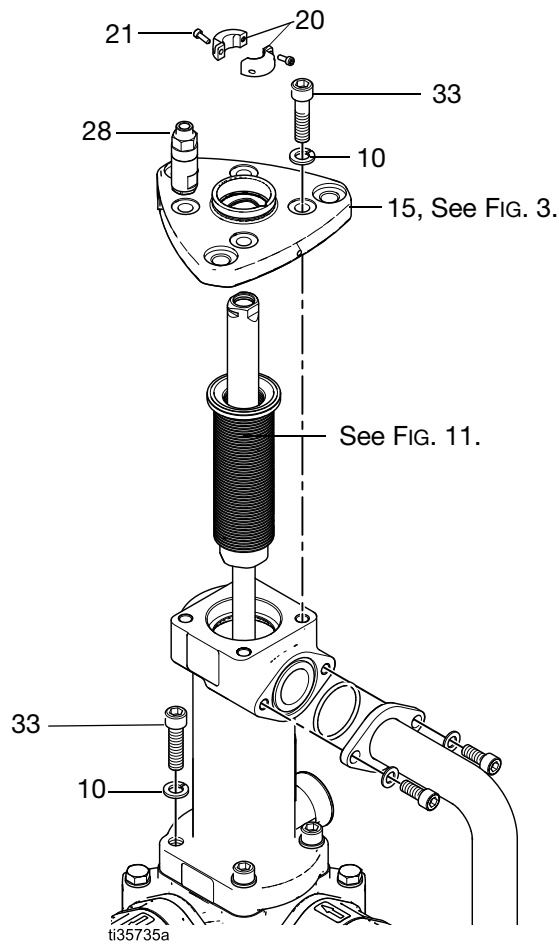
For all lubricants and adhesives, see the notes listed in **Parts (All Models)** on page 15.

1. Install the top plate assembly (15) (see FIG. 3, page 8), over the bellows assembly (14), by aligning the shapes of the bellows sleeve (22) and the backup seal (18). To orient as desired, rotate by 90° increments, aligning the bolt holes.



**FIG. 8. Rotate the Top Plate As Needed**

2. Apply removable (blue) Loctite<sup>®</sup> 243 to entire length of the threads on the capscrews (33). Install the four capscrews (33) with lock washers (10) in the top plate (15). This holds the bellows assembly (14) securely in place. Tighten the capscrews (33) uniformly and torque to 40-45 ft-lb (54-61 N•m).
3. If removed, apply thread sealant and install a new breather valve (28) in the port on the top plate. The valve must be installed so that it remains vertical.
4. Apply removable (blue) Loctite 243 to the screws (21). Install the retaining collar (20). Torque the screws to 18-22 in-lb (2-2.5 N•m).



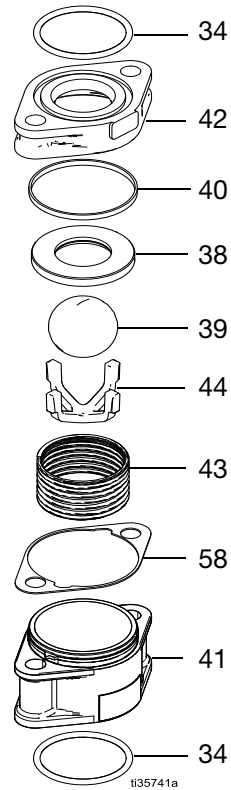
**FIG. 9. Disassemble or Reassemble the Bellows Section**

**Assemble Check Housings**

For all lubricants and adhesives, see the notes listed in **Parts (All Models)** on page 15.

1. Place compression spring (43) into the check valve housing (41).
2. Place the ball retainer (44) into the spring (see FIG. 10 on page 12). Insert the ball (39) into the ball retainer (44).

3. Install valve seat (38) over the ball (39) making sure the chamfer is facing down onto the ball (39).
4. Apply lubricant to the seat gasket (40) and install on the valve seat housing (42).
5. Place the valve seat housing (42) on top of the check valve housing (41) with the holes oriented approximately 90° apart. Apply light downward pressure to the valve seat housing (42), and rotate it, until it locks into the check valve housing (41). The holes should be lined up together.
6. Apply lubricant to both o-rings (34) and place one on the valve seat housing (42) and one on the check valve housing (41).
7. Repeat this process until four valve checks have been assembled.



**FIG. 10. Valve Check Housing Assembly**

## Install Manifolds

For all lubricants and adhesives, see the notes listed in **Parts (All Models)** on page 15.

1. Apply lubricant to o-ring (34) and place in the manifold section of the bellows chamber.
2. Apply removable (blue) Loctite® 243 to the entire length of the threads on the capscrews (45, 46). Install two of the capscrews (45) with washers (47) into the bottom flange holes of the inlet manifold and through an assembled check housing (41). See FIG. 10 for an assembled check housing.

Verify that the arrow on the check housing (41) is pointed towards the pump assembly. See **Parts (All Models)** on page 15 for check housing orientation. Loosely hand tighten the two capscrews (45) into the upper fluid housing (8).

3. Install the second assembled check housing (41) by running the capscrews (45) through the inlet manifold (49) middle flange and the assembled check housing (41). Verify that the arrow is pointing towards the pump assembly. Loosely hand tighten the capscrews (45) into the upper fluid housing (8).
4. Hand tighten capscrews (46) with washer (47) into the bellows chamber (13).
5. Tighten all capscrews (45, 46) on the inlet manifold (49) uniformly. Torque to 40-45 ft-lb (54-61 N•m).
6. Install two of the capscrews (45) with washers (47) into the bottom flange holes of the outlet manifold (51). Through an assembled check housing (41), verify that the arrow on the check housing (41) is pointed away from the pump assembly. See FIG. 12 on page 19 for check housing orientation. Loosely hand tighten the two capscrews into the bottom housing (7).
7. Install the top assembled check housing (41) by running the capscrews (45) through the outlet manifold (51) top flange and the assembled check housing (41). Verify that the arrow is pointing away from the pump assembly. Loosely hand tighten the capscrews (45) into the upper fluid housing (8).
8. Tighten all capscrews (45) on the outlet manifold (51) uniformly. Torque to 40-45 ft-lb (54-61 N•m).

## Replace the Bellows



This equipment stays pressurized until pressure is manually relieved. To help prevent serious injury from pressurized fluid, such as splashing fluid, follow the Pressure Relief Procedure in your separate pump manual when you stop dispensing and before replacing the bellows.

Follow these instructions to replace only the bellows, without full disassembly of the lower. Bellows Repair Kit 17K766 is available.

For all lubricants and adhesives, see the notes listed in **Parts (All Models)** on page 15.

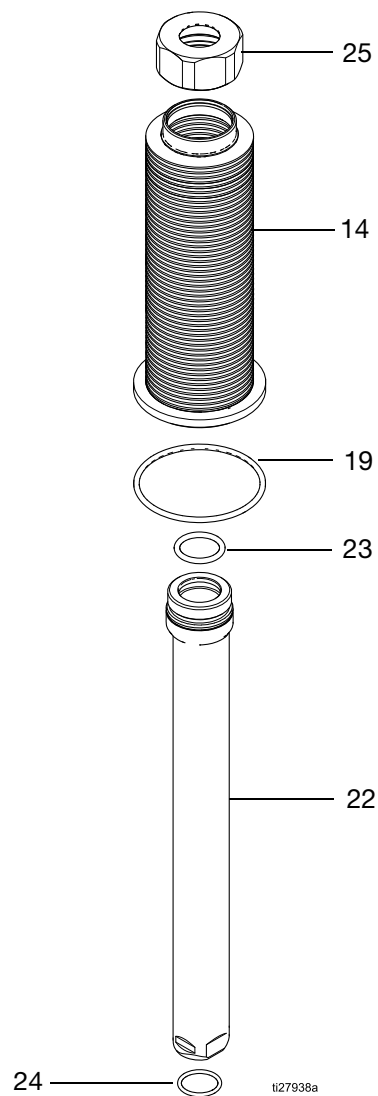
1. Follow steps 1–4 in **Preparation for Disassembly**, page 6, to relieve the pressure and prepare the lower for service.
  2. Secure the lower housing (8) in a vise.
  3. Remove the retaining collar (20) by removing the screws (21).
  4. Remove the four capscrews (33) and lock washers (10) from the top plate (15). This allows the bellows assembly to rotate with the top plate assembly. See FIG. 9, page 12.
  5. Carefully lift the top plate assembly (15) off of the bellows chamber (13). When removing keep the top plate (15) level.
- NOTE:** See FIG. 3, page 8. The retaining ring (27), retaining washer (26), bearing housing (16), bearing (17) and backup seal (18) nest in the top plate and will slide off with the top plate (15).
6. Carefully remove the retaining ring (27), retaining washer (26), bearing housing (16), bearing (17) and backup seal (18) from the top plate (15). See FIG. 3, page 8.
  7. Remove the bellows o-ring (19). See FIG. 4, page 9.
  8. Remove the bellows assembly from the bellows chamber (15). Remove the o-ring (23).
  9. If the bellows has failed, also remove the breather valve (28) from the top plate. Clean the fluid path of any clogged paint.

**NOTICE**

If the bellows has failed, the breather valve (28) must also be replaced and fluid path must be cleared of paint. Failure to replace the breather valve may cause potential damage and premature wear to your bellows.

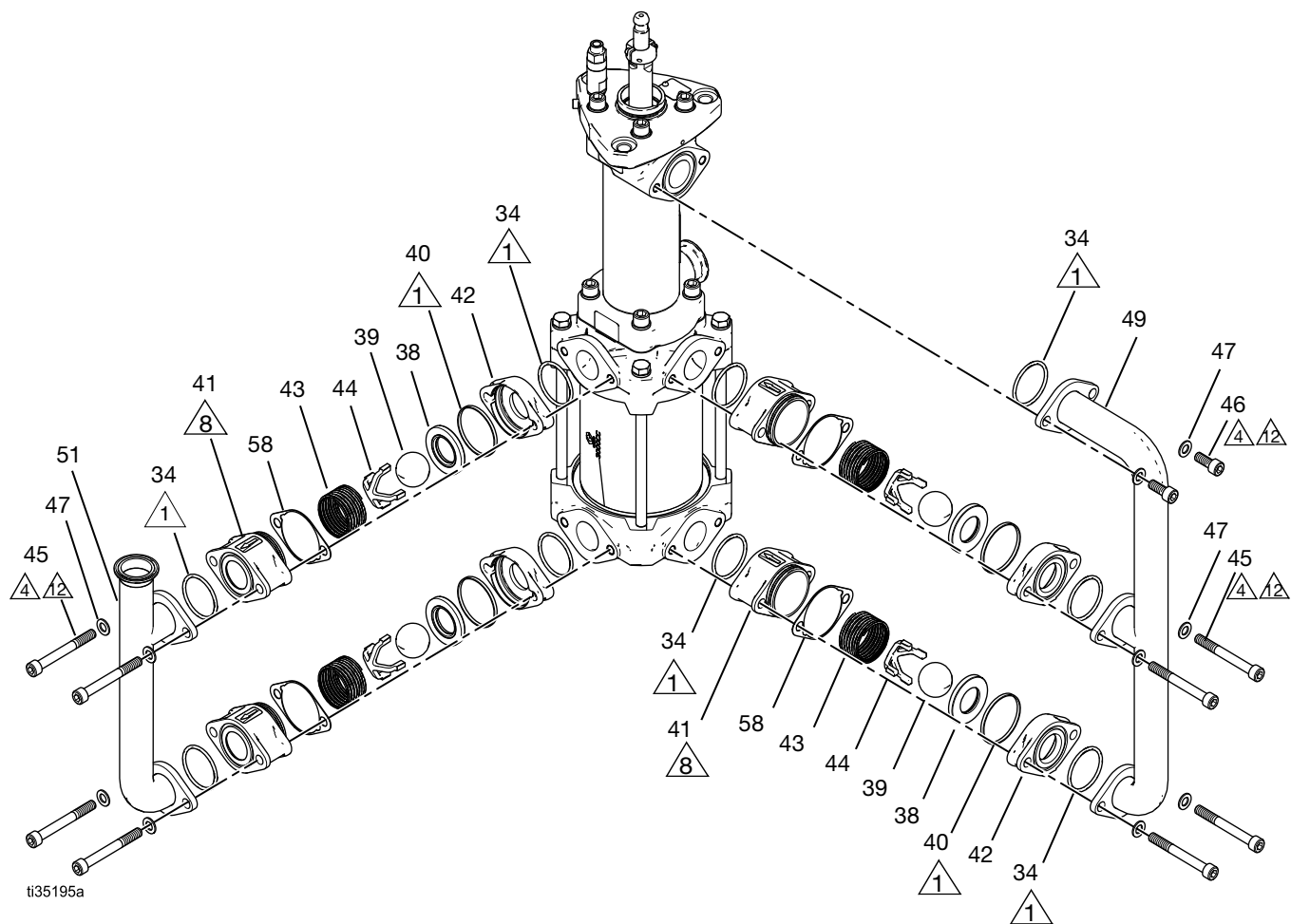
10. Clamp the flats of the bellows sleeve (22) in a vise.
11. Use a wrench on the flats of the bellows nut (25) to remove it from the bellows sleeve.
12. Remove the o-ring (24) from inside of the bellows sleeve (22).
13. Work the bellows (14) up and off the bellows sleeve (22).
14. Lubricate and install the o-ring (23).
15. Slide the new bellows (14) onto the bellows sleeve (22) and snap it into place.
16. Lubricate and install the o-ring (24) in the bellows sleeve.
17. Apply removable (blue) Loctite® 243 to the outside threads on the bellows sleeve.
18. Install the bellows nut (25) and torque to 25-30 ft-lb (34-41 N•m).
19. Insert the bellows assembly over the piston rod (3) and into the bellows chamber (13).
20. Lubricate and install the bellows o-ring (19).
21. Apply lubricant to the backup seal (18). Install the backup seal (18) into the top plate. Be sure the seal seats completely. Use a press if needed.
22. Install the retaining ring (27), retaining washer (26), bearing housing (16) and bearing (17) into the top plate (15). See FIG. 3, page 8.
23. If removed, apply thread sealant and install a new breather valve (28) in the port in the top of the top plate. The valve must be installed so that it remains vertical.
24. Install the top plate assembly over the bellows assembly, by aligning the shapes of the bellows sleeve (22) and the backup seal (18).

25. Apply removable (blue) Loctite® 243 to the entire length of the threads on the capscrews (33). Install the four capscrews (33) with lock washers (10) in the top plate (29). This holds the bellows assembly securely in place. Tighten the capscrews (33) uniformly and torque to 40-45 ft-lb (54-61 N•m).
26. Apply removable (blue) Loctite 243 to the screws (21). Install the retaining collar (20). Torque the screws to 18-22 in-lb (2-2.5 N•m).
27. Reconnect the lower to the motor as described in your separate pump manual.

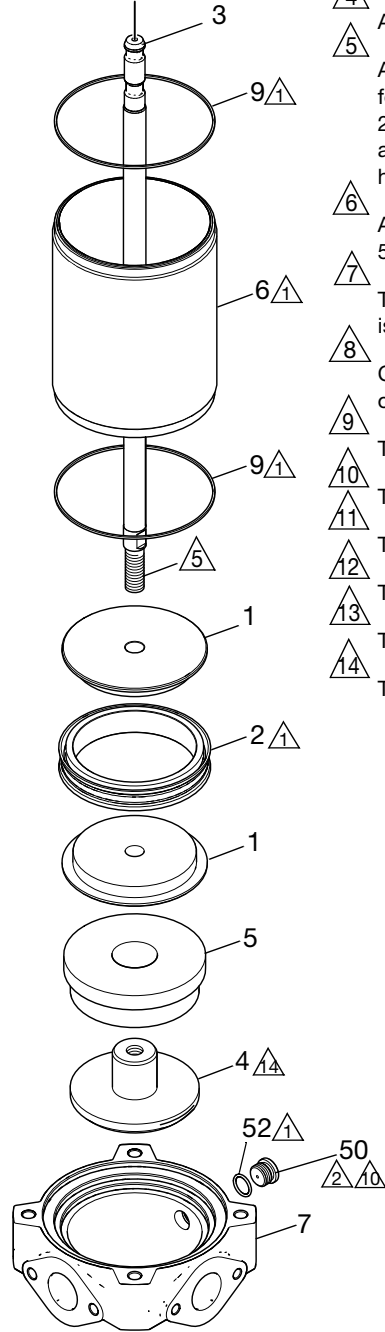
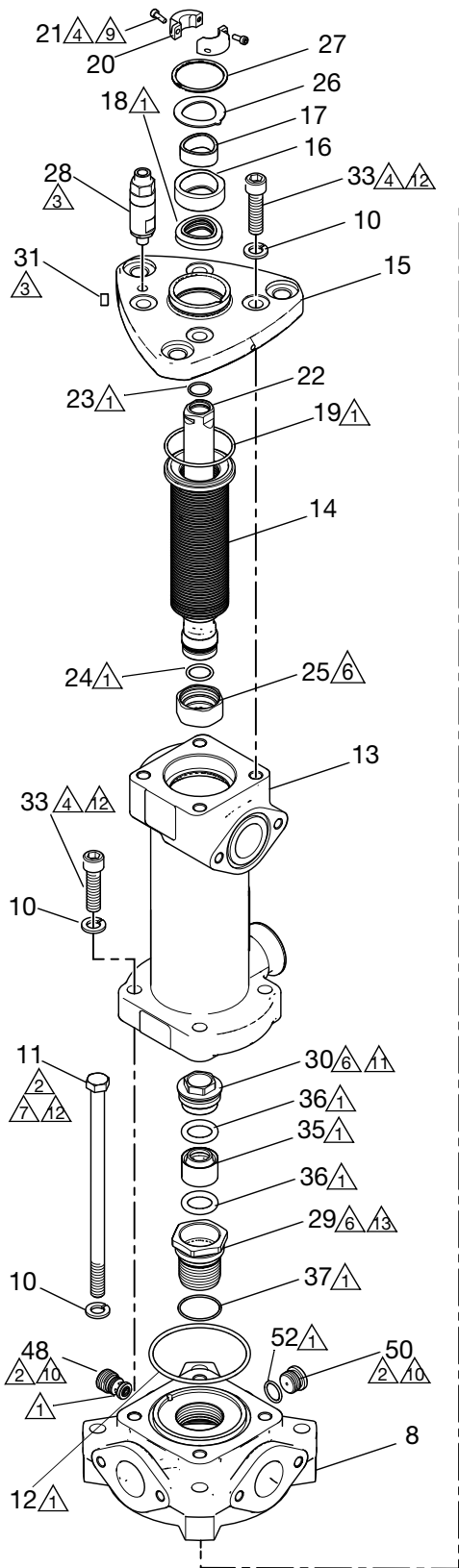


**FIG. 11. Replace the Bellows**

# Parts (All Models)



Parts (All Models)



- 1 Apply lubricant (Haynes® Tube Lubri-Film). Lubricant must contain no silicones.
- 2 Apply lubricant (Lubriplate® 930-AA).
- 3 Apply sealant (Loctite® 565™ PST Pipe Sealant).
- 4 Apply threadlocker (Loctite® 243).
- 5 Apply primer (degreasing solvent primer for Loctite products) and sealant (Loctite® 268). Assemble piston to piston rod and allow sealant to cure for a minimum of 12 hours before use.
- 6 Apply anti-seize lubricant paste (Loctite® 51269).
- 7 Tighten uniformly until cylinder (6) is seated.
- 8 Check valve assemblies. 41 shall be oriented as shown.
- 9 Torque to 18-22 in-lb (2-2.5 N•m)
- 10 Torque to 100-135 in-lb (11-15 N•m)
- 11 Torque to 25-30 ft-lb (34-41 N•m)
- 12 Torque to 40-45 ft-lb (54-61 N•m)
- 13 Torque to 70-75 ft-lb (95-102 N•m)
- 14 Torque to 95-100 ft-lb (129-136 N•m)

ti35196a



Ref.	Part	Description	Qty.
1	17T751	PISTON, 2500	2
	17T753	PISTON, 3000	2
	17T754	PISTON, 4000	2
2*◆	-----	SEAL, PISTON, 2500	1
	-----	SEAL, PISTON, 3000	1
	-----	SEAL, PISTON, 4000	1
3	17C104	ROD, PISTON, ULTRALIFE	1
	17G075	ROD, PISTION, CHROME**	1
4	17T758	NUT, PISTON	1
5	17T759	SPACER, PISTON, 2500	1
	17T760	SPACER, PISTON, 3000	1
	17T761	SPACER, PISTON, 4000	1
6	17T653	CYLINDER, ULTRALIFE, 2500CC	1
	17T762	CYLINDER, ULTRALIFE, 3000CC	1
	17T764	CYLINDER, ULTRALIFE, 4000CC	1
	17Y869	CYLINDER, CHROME, 2500CC	1
	17Y870	CYLINDER, CHROME, 3000CC	1
	17Y871	CYLINDER, CHROME, 4000CC	1
7	17Y143	HOUSING, BOTTOM	1
8	17Y145	HOUSING, TOP	1
9*◆	17T766	GASKET, 2500CC CYLINDER	2
	17T767	GASKET, 3000CC CYLINDER	2
	17T768	GASKET, 4000CC CYLINDER	2
10	108792	WASHER, LOCK	12
11	17Y415	SCREW, CAP, HEX HJD	4
12*	112358	PACKING, O-RING	1
13	17T652	CHAMBER, BELLOWS	1
14*‡	-----	BELLOWS, KNIFE	1
15	17Y138	PLATE, PUMP, MOUNT	1
16	17J438	CARTRIDGE, SEAL HOUSING	1
17*‡	-----	BEARING, MOLDED	1
18*‡	-----	SEAL, SHAFT, BACKUP	1
19‡	117283	PACKING, O-RING	1
20	17B610	COLLAR, SPLIT	2
21	116475	SCREW, SHCS, M4X12	2
22	17G191	SLEEVE, TRI-LOBE	1
23*‡	117610	O-RING	1
24*‡	188554	PACKING, O-RING	1
25	17D102	NUT, BELLOW	1
26	17Z053	WASHER, SEAL, RETAINER	1

27	120762	RING, RETAINER	1
28	17J564	VALVE, CHECK, ASSEMBLY	1
29	17G404	CARTRIDGE, SEAL, HOUSING	1
30	17G403	NUT, THROAT	1
31	110208	PLUG, PIPE, HEADLESS	1
33	17Y303	SCREW, SHCS, M12X45, SST	8
34*◆#	166985	PACKING, O RING	9
35*†	-----	SEAL, ROD, THROAT	1
36*†	-----	O-RING	2
37	107098	PACKING, O-RING	1
38*#	-----	SEAT, VALVE	4
39*#	-----	BALL, METALLIC	4
40*#	-----	GASKET, SEAT, VALVE	4
41	17T730	HOUSING, VALVE, CHECK	4
42	17T731	HOUSING, SEAT, VALVE, CHECK	4
43*#	-----	SPRING, COMPRESSION	4
44*#	-----	RETAINER, BALL	4
45	124936	SCREW, SHCS, M10-1.5X90, SST	8
46	25D883	SCREW, CAP, SOCKET HD	2
47	112914	WASHER, PLAIN	10
48	25D857	VALVE, RELIEF, PRESSURE	1
49	17T787	MANIFOLD, INLET	1
50	561460	PLUG, OUTLET SST 3/4-16 SAE	2
51	19Y342	MANIFOLD, OUTLET, 2500CC	1
	17T792	MANIFOLD, OUTLET, 3000CC, 4000CC	1
52	558730	O-RING, -908 VITON	2
56▲	16K116	LABEL, NOTICE	1
57	172479	SAFETY TAG	1
58*#	-----	SPACER PLATE	4

----- Parts not sold separately.

▲ Replacement Safety labels, tags, and cards are available at no cost.

\* Parts are included in the Complete Pump Repair Kit. See **Repair Kits**.

\*\* Use this component only when required for chemical compatibility. Use may result in a reduced cycle life.

# Parts included in Check Valve Repair Kit. See **Repair Kits**.

† Parts are included in Lip Seal Kit 17K753.

◆ Parts are included in the Piston Seal Kits. See **Repair Kits**.

‡ Parts are included in Bellows Repair Kit 17K766.

# Repair Kits

Description	Lower Size		
	2500cc	3000cc	4000cc
Complete Pump Repair Kit (*) Includes Refs. 2, 9, 12, 14, 17, 18, 23, 24, 34, 35, 36, 38, 39, 40, 43, 44, and 58.	25E755	25E756	25E757
Chromex Piston Rod (**)	17G075		
Lip Seal Kit (†) Includes Refs. 35 and 36.	17K753		
UHMWPE Piston Seal Kit (Standard) (◆, **) Includes Refs. 2, 9, and 34.	25E752	25E753	25E754
PTFE Piston Seal Kit (◆, **) Includes Refs 2, 9, 34	20B496	20B497	20B495
Bellows Repair Kit (‡) Includes Refs. 14, 17, 18, 19, 23, and 24.	17K766		
Check Valve Repair Kit (#) Includes Refs. 34 (qty 2), 38, 39, 40, 43, 44, and 58. Quantities for all are 1 except 34.	25E751		
Complete Check Assembly Includes Refs. 38, 39, 40, 41, 42, 43, 44, and 58.	17T727		
Check Valve with Silicone Nitride Balls Repair Kit Includes Refs. 34 (qty 2), 38, 39, 40, 43, 44, and 58. Quantities for all are 1 except 34.	25F143		
Complete Check Valve Assembly with Silicone Nitride Balls Includes Refs. 38, 39, 40, 41, 42, 43, 44, and 58.	18D409		

\*\* Use these components only when required for chemical compatibility. Use may result in a reduced cycle life.

## Connection Kits

The following kits include tie rods, couplings, shields, and other components to connect the sealed 4-Ball Plus Lowers to the following motor/pump style.

Motor/Pump Style	Connection Kit
Viscount I	Not recommended
Viscount II	17K520
NXT 2200	Not recommended
NXT 3400, 6500	17Z549
XL 3400, 6500	17Z549

Motor/Pump Style	Connection Kit
E-Flo	Not recommended
E-Flo DC (1 hp)	Not recommended
E-Flo DC (2 hp)	17K525
E-Flo DCx2	17K525
Bulldog	17K517
Senator, President	Not recommended

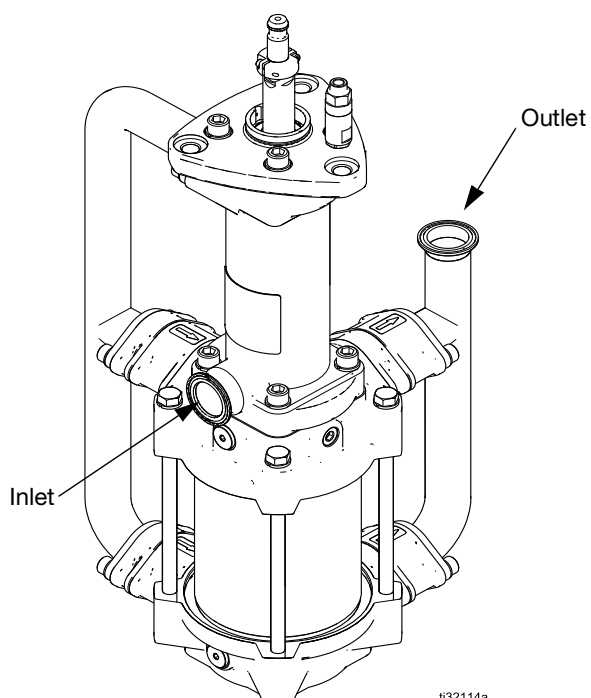
# Dimensions

## Identifying Inlet and Outlet

When installing or reinstalling the sealed 4-ball plus lowers, identify the inlet and outlet of the sealed 4-ball plus lowers, and follow the recommended installation procedures in the corresponding pump manuals. See **Related Manuals** on page 3.

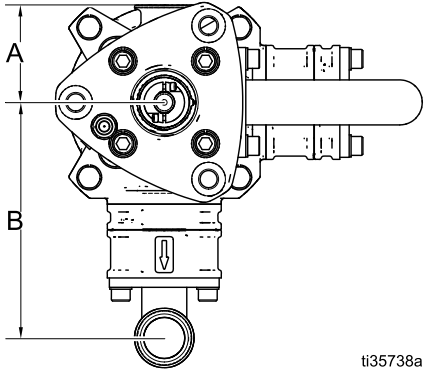
### NOTICE

The maximum fluid inlet pressure is 15 psi (0.1 MPa, 1.0 bar). Damage to the bellows may occur if you exceed this pressure. Do not use another pump or checking device to supply the bellows pump.



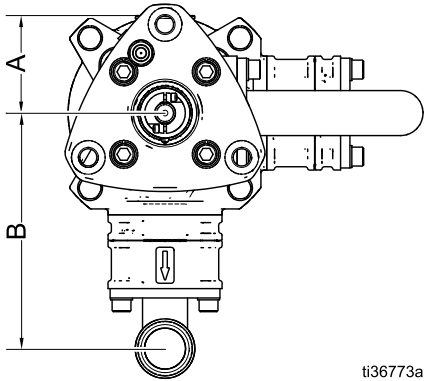
**FIG. 12. Inlet and Outlet**

**Standard Top Plate Rotation**



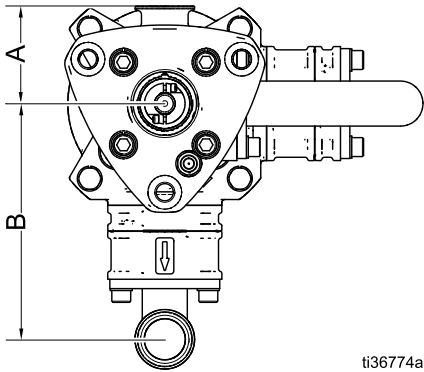
ti35738a

**90° Top Plate Rotation**

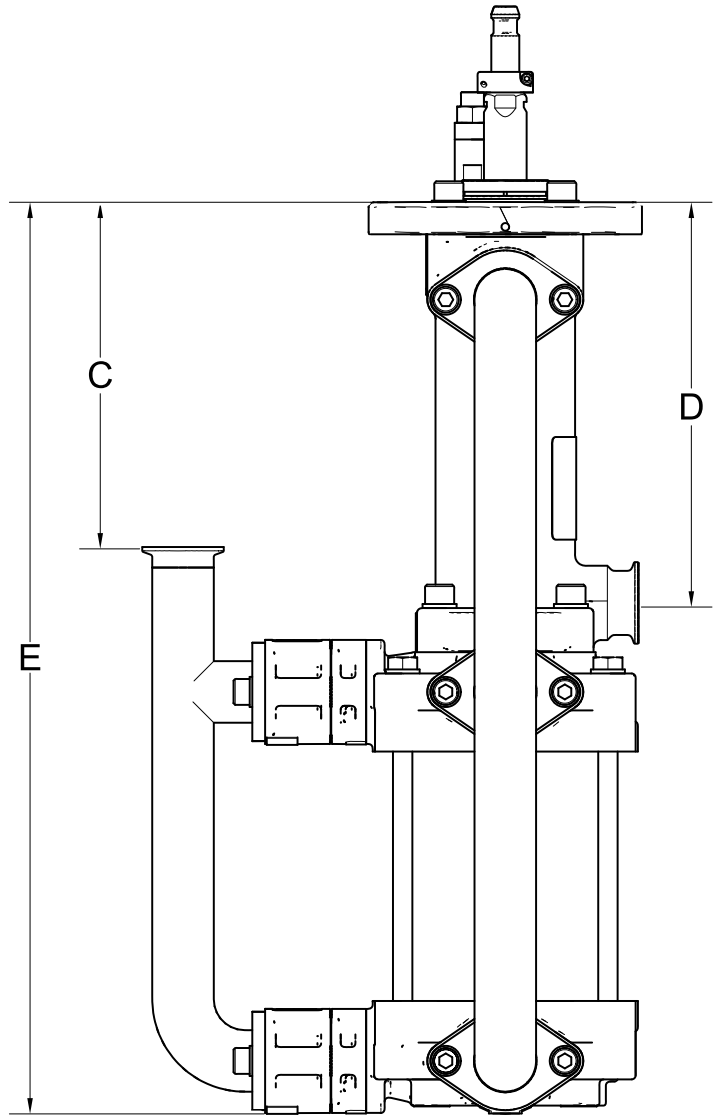


ti36773a

**180° Top Plate Rotation**



ti36774a



Dimension	U.S.	Metric
A	3.3 in.	8.4 cm
B	8.2 in. (2500cc) 7.9 in. (3000cc, 4000cc)	20.8 cm (2500cc) 20 cm (3000cc, 4000cc)
C	9.2 in. (2500cc) 8.4 in. (3000cc, 4000cc)	23.4 cm (2500cc) 21.3 cm (3000cc, 4000cc)
D	9.7 in.	24.6 cm
E	22.2 in.	56.4 cm

# Technical Specifications

4-Ball Pump Lowers (2500cc, 3000cc, and 4000cc Sizes)				
	Maximum Fluid Working Pressure (U.S./Metric)	Displacement per Cycle (4.75 in. [12 cm] stroke)	Maximum Recommended Cycle Rate	Weight (U.S./Metric)
Model 17Z387 Model 17Z390 Model 17Z695 Model 17Z698 Model 18F379	460 psi 32 bar (3.2 mPa)	2500cc	12 cycles per minute	76 lb. (34.5 kg)
Model 17Z388 Model 17Z391 Model 17Z696 Model 17Z699 Model 18F380	400 psi 27.6 bar (2.8 mPa)	3000cc		77 lb. (35 kg)
Model 17Z389 Model 17Z392 Model 17Z697 Model 17Z700 Model 18F381	300 psi 20.7 bar (2.0 mPa)	4000cc		79 lb. (36 kg)

	Maximum Fluid Temperature Rating	Fluid Inlet and Outlet Sizes	Wetted Parts
2500cc	150°F 66°C	1-1/2 in. Sanitary Quick Clamp	Stainless Steel, PTFE, Ultra-High Molecular Weight Polyethylene, Tungsten Carbide, Fluoropolymer, Polyphenylene Sulfide (PPS), Nylon
3000cc			
4000cc			

All trademarks or registered trademarks are the property of their respective owners.

## California Proposition 65

### CALIFORNIA RESIDENTS

 **WARNING:** Cancer and reproductive harm. – [www.P65warnings.ca.gov](http://www.P65warnings.ca.gov).

# Graco Standard Warranty

Graco warrants all equipment referenced in this document which is manufactured by Graco and bearing its name to be free from defects in material and workmanship on the date of sale to the original purchaser for use. With the exception of any special, extended, or limited warranty published by Graco, Graco will, for a period of twelve months from the date of sale, repair or replace any part of the equipment determined by Graco to be defective. This warranty applies only when the equipment is installed, operated and maintained in accordance with Graco's written recommendations.

This warranty does not cover, and Graco shall not be liable for general wear and tear, or any malfunction, damage or wear caused by faulty installation, misapplication, abrasion, corrosion, inadequate or improper maintenance, negligence, accident, tampering, or substitution of non-Graco component parts. Nor shall Graco be liable for malfunction, damage or wear caused by the incompatibility of Graco equipment with structures, accessories, equipment or materials not supplied by Graco, or the improper design, manufacture, installation, operation or maintenance of structures, accessories, equipment or materials not supplied by Graco.

This warranty is conditioned upon the prepaid return of the equipment claimed to be defective to an authorized Graco distributor for verification of the claimed defect. If the claimed defect is verified, Graco will repair or replace free of charge any defective parts. The equipment will be returned to the original purchaser transportation prepaid. If inspection of the equipment does not disclose any defect in material or workmanship, repairs will be made at a reasonable charge, which charges may include the costs of parts, labor, and transportation.

**THIS WARRANTY IS EXCLUSIVE, AND IS IN LIEU OF ANY OTHER WARRANTIES, EXPRESS OR IMPLIED, INCLUDING BUT NOT LIMITED TO WARRANTY OF MERCHANTABILITY OR WARRANTY OF FITNESS FOR A PARTICULAR PURPOSE.**

Graco's sole obligation and buyer's sole remedy for any breach of warranty shall be as set forth above. The buyer agrees that no other remedy (including, but not limited to, incidental or consequential damages for lost profits, lost sales, injury to person or property, or any other incidental or consequential loss) shall be available. Any action for breach of warranty must be brought within two (2) years of the date of sale.

**GRACO MAKES NO WARRANTY, AND DISCLAIMS ALL IMPLIED WARRANTIES OF MERCHANTABILITY AND FITNESS FOR A PARTICULAR PURPOSE, IN CONNECTION WITH ACCESSORIES, EQUIPMENT, MATERIALS OR COMPONENTS SOLD BUT NOT MANUFACTURED BY GRACO.** These items sold, but not manufactured by Graco (such as electric motors, switches, hose, etc.), are subject to the warranty, if any, of their manufacturer. Graco will provide purchaser with reasonable assistance in making any claim for breach of these warranties.

In no event will Graco be liable for indirect, incidental, special or consequential damages resulting from Graco supplying equipment hereunder, or the furnishing, performance, or use of any products or other goods sold hereto, whether due to a breach of contract, breach of warranty, the negligence of Graco, or otherwise.

## **FOR GRACO CANADA CUSTOMERS**

The Parties acknowledge that they have required that the present document, as well as all documents, notices and legal proceedings entered into, given or instituted pursuant hereto or relating directly or indirectly hereto, be drawn up in English. Les parties reconnaissent avoir convenu que la rédaction du présente document sera en Anglais, ainsi que tous documents, avis et procédures judiciaires exécutés, donnés ou intentés, à la suite de ou en rapport, directement ou indirectement, avec les procédures concernées.

# Graco Information

For the latest information about Graco products, visit [www.graco.com](http://www.graco.com).

For patent information, see [www.graco.com/patents](http://www.graco.com/patents).

**TO PLACE AN ORDER**, contact your Graco distributor or call to identify the nearest distributor.

**Phone:** 612-623-6921 **or Toll Free:** 1-800-328-0211 **Fax:** 612-378-3505

*All written and visual data contained in this document reflects the latest product information available at the time of publication. Graco reserves the right to make changes at any time without notice.*

Original instructions. This manual contains English. MM

**Graco Headquarters:** Minneapolis

**International Offices:** Belgium, China, Japan, Korea

**GRACO INC. AND SUBSIDIARIES • P.O. BOX 1441 • MINNEAPOLIS MN 55440-1441 • USA**  
**Copyright 2021, Graco Inc. All Graco manufacturing locations are registered to ISO 9001.**

[www.graco.com](http://www.graco.com)  
Revision J, November 2023